

Electrically-heated vat 55°C

USES



With a capacity of **50 to 650 litres**, this vat is for **heating milk** to a maximum temperature of **55°C**. Easy to use, this vat is suitable heating the milk manually for small production runs of cheese.

NB: it is not suitable for pasteurisation.

In order to **improve the working position** this vat can be fitted with a walkway making draining and working at height easier.

TECHNICAL DETAILS

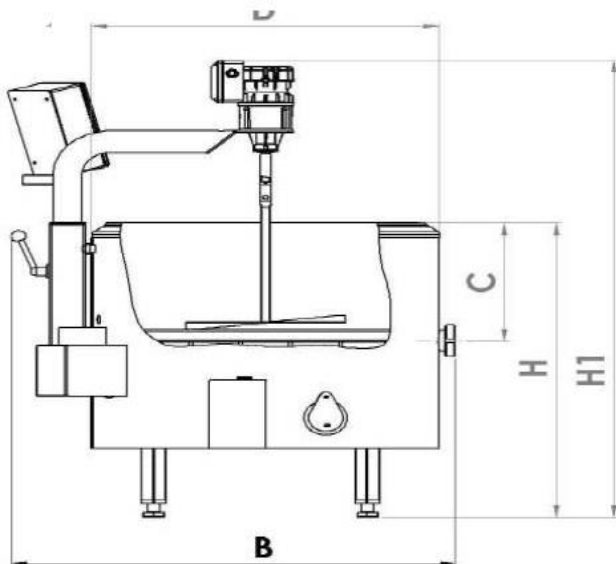

Photo for information only

Type	Power (kW)	Dimensions (mm)						Cold-water inlet	Cold-water outlet	Weight (kg)
		D	H	H1	C	E	B			
SK 50	4	∅550	450	900	260	950	680	1/2"	1/2"	65
SK 100	6	∅ 750	450	900	260	950	880	1/2"	1/2"	98
SK 200	10	∅ 850	600	960	350	1100	1000	1/2"	1/2"	135
SK 300	12	∅ 1000	620	980	350	1100	1150	3/4"	3/4"	185
SK 500	12	∅ 1140	775	1000	450	1300	1300	3/4"	3/4"	270
SK 650	15	∅ 1305	775	1000	450	1300	1460	3/4"	3/4"	305

This double-walled vat is electrically heated with an electronic thermometer and a 25rpm mixer agitator. Curd cutting is carried out manually.

Also:

- Two-part lid.
- Butterfly valve DN50.

NB: Not suitable for pasteurisation (maximum operating temperature 55°C)



OPTIONS

- Electronic speed controller.
- Programmable controller with four programmes.
- Working platform.