

SELF-PRIMING PUMP

FOR WHAT USE ?

Liquid ring pump for transferring milk, water or non-viscous food liquids.



TECHNICAL DETAILS

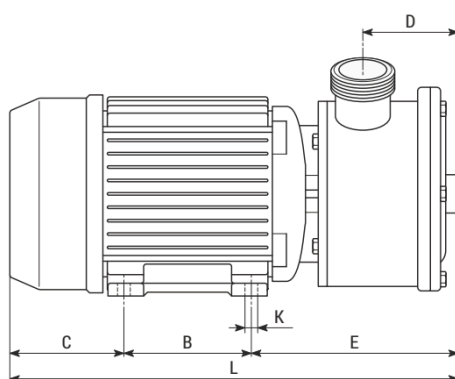
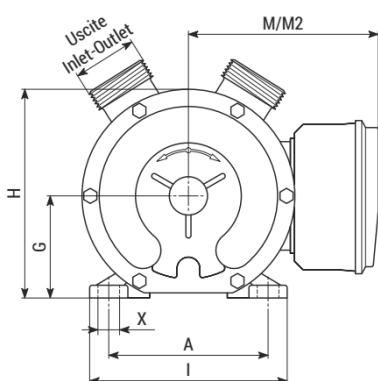

OPTIONS



measurements in mm

Model	Connection	Voltage	Weight	A	B	C	D	E	G	H	I	K	L
Junior pump	SMS 38m	0.45kw 220V Single	9.6kg	112	90	78	50	168	71	137	136	8	336
Senior pump	SMS 38m	0.75 Kw 220 V Single	17.6 kg	125	100	90	76	170	80	165	155	10	360

Model sénior :

- Reversible self-priming pump
- 316 stainless steel body
- Motor: 220 V / 0.75 KW with reversing reverser
- Flow rate: 3750 l at 1.5bars 2500 l/h at 2 bars
- Inlet: 38 SMS
- Output: 38 SMS
- Weight: 17.6 kg

Model junior :

- Reversible self-priming pump
- 316 stainless steel body
- Motor: 220 V / 0.45 KW with reversing reverser
- Flow rate: 1500L at 1.5 Bar
- Input: 38 SMS
- Output: 38 SMS
- Weight: 9.5 KG

